

5190243IB02

2020290756

Report No: 2020290756  
Applicant: TAFPRINT LTD.  
Tafprint LTD. Plovdiv 4023, Nedyalka Shileva 16. Bulgaria  
Contact Person: Dimitar Tafkov  
Contact Telephone: 0035932654160  
Contact e-mail: office@tafprint.com  
Sample Accepted on: 09.07.2020  
Report Date: 29.07.2020  
Total number of pages: 10 (Pg)

Sample ID: Medical Face Mask

TEST	METHOD	Specimen	RESULT
* Medical face masks - Requirements and test methods	EN 14683+AC 2019	Medical Face Mask	PASS
			TYPE IIR



Seal



Customer Representative  
Hasan KUTLU



Laboratory Manager  
Hava SARIAYDIN

**EUROLAB ® (TÜRCERT TEKNİK KONTROL VE BELGELENDİRME A.Ş.)**

It is prohibited to change any and all versions of this document in any manner whatsoever. In case of a conflict between the electronic version (e.g. PDF file) and the original paper version provided by EUROLAB®, the latter will prevail.

TÜRCERT Teknik Kontrol ve Belgelendirme A.Ş. disclaim liability for any direct, indirect, consequential or incidental damages that may result from the use of the information or data, or from the inability to use the information or data contained in this document.

The contents of this report may only be transmitted to third parties in its entirety and provided with the copyright notice, prohibition to change, electronic versions' validity notice and disclaimer.

**Environment**

The requirements and standards apply to equipment intended for use in

<b>X</b>	Residential (domestic) environment
<b>X</b>	Commercial and light-industrial environment
<b>X</b>	Industrial environment
<b>X</b>	Medical environment

## Scope

This European Standard specifies construction, design, performance requirements and test methods for medical face masks intended to limit the transmission of infective agents from staff to patients during surgical procedures and other medical settings with similar requirements.

## Requirements and Test Methods

1. Bacterial Filtration Efficiency
2. Differential Pressure
3. Splash Resistance Pressure
4. Microbial Cleanliness

All tests shall be carried out on finished products or samples cut from finished products, if applicable in their sterile state.

### 1. Method for in-vitro determination of bacterial filtration efficiency (BFE)

#### Principle

A specimen of the mask material is clamped between a six-stage cascade impactor and an aerosol chamber. An aerosol of *Staphylococcus aureus* is introduced into the aerosol chamber and drawn through the mask material and the impactor under vacuum. The bacterial filtration efficiency of the mask is given by the number of colony forming units passing through the medical face mask material expressed as a percentage of the number of colony forming units present in the challenge aerosol.

#### Reagents and materials

Describe commercially available solutions of tryptic soy agar, tryptic soy broth and peptone water.

#### Tryptic soy agar

Formula/liter:

Enzymatic digest of casein	15 g
Enzymatic digest of soybean meal	5 g
Sodium chloride	5 g
Agar	15 g
Final pH	7,3 ± 0,2 at 25 °C

**Tryptic soy broth**

Formula/liter:

Enzymatic digest of casein	17 g
Enzymatic digest of soybean meal	3 g
Sodium chloride	5 g
Dextrose	2,5 g
Final pH	7,3 ± 0,2 at 25 °C

**Peptone Water**

Formula/liter:

Peptone	1 g
Sodium chloride	5 g
Final pH	7,3 ± 0,2 at 25 °C

**Preparation of bacterial challenge**

Staphylococcus aureus shall be inoculated into 30 ml tryptic soy broth in an Erlenmeyer flask and incubated with mild shaking at a temperature of (37 ± 2) °C for (24 ± 2) h. The culture shall then be diluted in peptone water to give a concentration of approximately 5 × 10<sup>5</sup> cfu/ml.

The bacterial challenge shall be maintained at (2 200 ± 500) cfu per test. The bacterial challenge shall be determined on the basis of experience and previous positive control plates (see B.6.3) and the dilution of the challenge suspension adjusted accordingly. The mean particle size in the bacterial challenge shall be maintained at (3,0 ± 0,3) µm (see B.6.9).

**Procedure**

Assemble the apparatus in accordance with the flow chart shown in Figure 1.

Deliver the bacterial challenge to the nebulizer using the peristaltic or syringe pump.

Perform a positive control run without a test specimen. Initiate the bacterial challenge by turning on the vacuum pump and adjust the flow rate through the cascade impactor to 28,3 l/min. Deliver the bacterial challenge for 1 min. Maintain the airflow through the impactor for 2 min. Then remove the plates from the impactor. Ensure that each plate is numbered to indicate its position in the impactor.

Place fresh plates in the impactor, fix a test specimen in place and repeat the above procedure.

Repeat this procedure for each test specimen.

After the last test specimen has been tested, perform a further positive control run.

Perform a negative control run by passing air, without addition of the bacterial challenge, through the cascade impactor for 2 min.

Incubate all the plates at  $(37 \pm 2) ^\circ\text{C}$  for  $(48 \pm 4)$  h. For each specimen and control run, count the number of colonies on each plate and add up the counts to give the total number of cfu collected by the impactor using the "positive hole" conversion Table1 in accordance with the instructions of the cascade impactor manufacturer. For the two positive control runs, take the mean of the two totals. From the positive control plates calculate the mean particle size of the bacterial challenge aerosol using the "positive hole" conversion table in accordance with the instructions of the cascade impactor manufacturer.

### Calculation of bacterial filtration efficiency

For each test specimen calculate the bacterial filtration efficiency B, as a percentage, using the following formula:

$$B = (C - T) / C \times 100$$

Where;

C is the mean of the total plate counts for the two positive control runs;

T is the total plate count for the test specimen.

## 2. Method For Determination of Breathability (Differential Pressure)

### Principle

A device which measures the differential pressure required to draw air through a measured surface area at a constant air flow rate is used to measure the air exchange pressure of the medical face mask material, as shown in Figure 1. Water-filled manometers (M1 and M2) are used to measure the differential pressure. A flow meter is used for measurement of the airflow. An electric vacuum pump draws air through the apparatus and a needle valve is used to adjust the airflow rate.

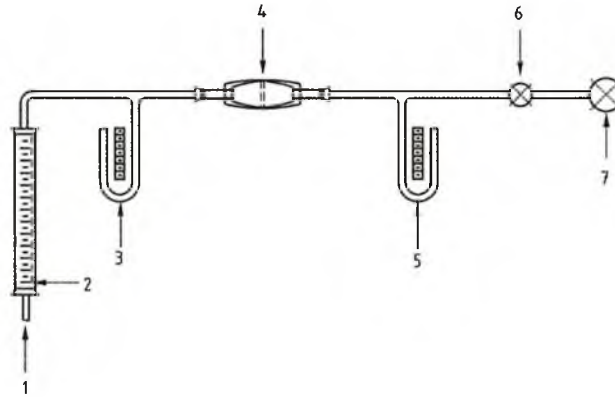

### Key

- 1 air inlet
- 2 flow meter
- 3 manometer M1
- 4 filter material

- 5 manometer M2
- 6 valve
- 7 vacuum pump

**Figure 1 — Apparatus for measuring air resistance**

### Procedure

The test specimen is placed across the 2,5 cm diameter orifice (total area 4,9 cm<sup>2</sup>) and clamped into place so as to minimise air leaks and that the tested area of the specimen will be in line and across the flow of air.

The pump is started and the flow of air adjusted to 8 l/min.

The manometers M1 and M2 are read and recorded.

The procedure described in steps 1 through 3 is carried out on 5 (or appropriate number of) different areas of the mask and the readings averaged.

### Calculation of differential pressure

For each test specimen calculate the differential pressure  $\Delta P$  as follows:

$$\Delta P = (X_{m1} - X_{m2})/4,9$$

Where;

$X_{m1}$  is pressure in Pa, manometer M1, mean of 5 test areas, low pressure side of the material;

$X_{m2}$  is pressure in Pa, manometer M2, mean of 5 test areas, high pressure side of the material;

4,9 is the cm<sup>2</sup> area of the test material;

$\Delta P$  is the differential pressure per cm<sup>2</sup> of test material expressed in Pa.

### 3. Splash Resistance

When tested in accordance with ISO 22609 the resistance of the medical face mask to penetration of splashes of liquid shall conform to the minimum value given for Type IIR in Table 1.

### 4. Microbial Cleanliness (Bioburden)

When tested according to EN ISO 11737-1 the bioburden of the medical mask shall be  $\leq 30$  cfu/g tested (see Table 1).

To determine the mask's bioburden according to EN ISO 11737-1, follow the procedure below:

The number of masks that shall be tested is minimum 5 (five), but can be greater if necessary to allow for an AQL of 4 %.

Weigh each mask prior testing. The full mask is aseptically removed from the packaging and placed in a sterile 500 ml bottle containing 300 ml of extraction liquid (1 g/l Peptone, 5 g/l NaCl & 2 g/l polysorbate surfactant 20 [e.g. Tween 20, Alkest TW 20]).

The bottle is laid down on an orbital shaker and shaken for 5 min at 250 rpm. After this extraction step, 100 ml of the extraction liquid is filtered through a 0,45  $\mu$  filter and laid down on a TSA plate for the total viable aerobic microbial count. Another 100 ml aliquot of the same extraction liquid is filtered in the same way and the filter plated on Sabouraud Dextrose agar (SDA) with chloramphenicol for fungi enumeration. The plates are incubated for 3 days at 30 °C and 7 days at (20 – 25) °C for TSA and SDA plates respectively.

The total bioburden is expressed by addition of the TSA and SDA counts.

In the report, indicate the total bioburden per mask and based on the mask weigh, the total bioburden per gram tested.

**TEST REQUIREMENTS**

Test	Type I <sup>a</sup>	Type II	Type IIR
Bacterial filtration efficiency (BFE), (%)	≥ 95	≥ 98	≥ 98
Differential pressure (Pa/cm <sup>2</sup> )	< 40	< 40	< 60
Splash resistance pressure (kPa)	Not required	Not required	≥ 16,0
Microbial cleanliness (cfu/g)	≤ 30	≤ 30	≤ 30

<sup>a</sup> Type I medical face masks should only be used for patients and other persons to reduce the risk of spread of infections particularly in epidemic or pandemic situations. Type I masks are not intended for use by healthcare professionals in an operating room or in other medical settings with similar requirements.

**TEST RESULTS**

EN 14683 Inspection

SAMPLE : Medical Face Mask

Test	Type			Result	Evaluation	
Bacterial filtration efficiency (BFE), (%)	1 ≥ 95	2 ≥ 98	2R ≥ 98	99.11	99.10	PASS
				99.08		
				99.09		
				99.13		
				99.10		
Differential pressure (Pa/cm <sup>2</sup> )	< 40	< 40	< 60	28	PASS	
Splash resistance pressure (kPa)	N/A	N/A	≥ 16,0	19	Type IIR	
Microbial cleanliness (cfu/g)	≤ 30			18	PASS	

Free Area



**MASK IMAGES UNDER THE TEST**



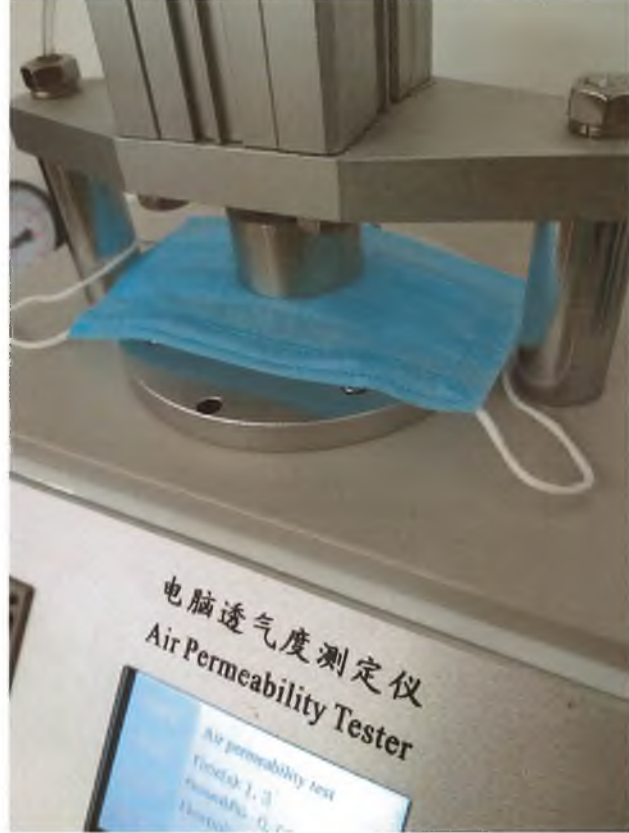

\*\*\* End of Report \*\*\*